

# ***Shark***<sup>®</sup>

## **ROTATOR**<sup>®</sup>

**FREESTYLE PRO CORDLESS**

### **SV1112**

**Series**

---

**INSTRUCTIONS**



sharkclean.com



1-800-798-7398

# THANK YOU

for purchasing the Shark® Rotator® Freestyle PRO Cordless Vacuum

---



**TIP:** You can find the model number and date code on the rating label located behind the dust cup on your unit.

## REGISTER YOUR PURCHASE



registeryourshark.com



1-800-798-7398

## RECORD THIS INFORMATION

Model Number: \_\_\_\_\_

Date Code: \_\_\_\_\_

Date of Purchase (Keep receipt): \_\_\_\_\_

Store of Purchase: \_\_\_\_\_

## TECHNICAL SPECIFICATIONS

Voltage: 14.4V

## PLEASE READ CAREFULLY AND KEEP FOR FUTURE REFERENCE.

This Owner's Guide is designed to help you get a complete understanding of your new Shark Rotator Freestyle PRO Cordless Vacuum.

If you have any questions, please call the customer service line at 1-800-798-7398.

# CONTENTS

---

|   |           |
|---|-----------|
| <b>Important Safety Instructions</b> .....  | <b>3</b>  |
| <b>Getting to Know Your Shark® Rotator® Freestyle<br/>PRO Cordless Vacuum</b> ..... | <b>5</b>  |
| <b>Assembling Your Vacuum</b> .....   | <b>7</b>  |
| How do I Know When the Vacuum is Charged? .....                                     | 7         |
| <b>Using Your Vacuum</b> .....  | <b>9</b>  |
| <b>Maintenance</b> .....  | <b>11</b> |
| Emptying the Dust Cup .....   | 11        |
| Cleaning the Filter .....   | 12        |
| Blockages in Nozzle .....   | 13        |
| Cleaning the Brushroll .....  | 14        |
| Blockages in Main Unit .....  | 14        |
| <b>Brushroll Removal and Insertion</b> .....  | <b>15</b> |
| <b>Battery Pack Replacement and Disposal</b> .....                                  | <b>17</b> |
| <b>Maximizing the Life of Your Battery</b> .....                                    | <b>18</b> |
| <b>Troubleshooting Guide</b> .....  | <b>19</b> |
| <b>Warranty</b> .....   | <b>22</b> |

# IMPORTANT SAFETY INSTRUCTIONS

## FOR HOUSEHOLD USE ONLY

---

### **⚠ WARNING**

**To reduce the risk of injury, fire, electric shock, and property damage resulting from improper use of the appliance, carefully observe the following instructions. This unit contains electrical connections and moving parts that potentially present risk to the user.**

#### **THE POWER NOZZLE CONTAINS ELECTRICAL CONNECTIONS:**

- These are not serviceable parts.
  - DO NOT use to vacuum any liquids.
  - DO NOT immerse in water.
- .....

- 1** Inspect charging adapter cord and plug for any damage before use. DO NOT use vacuum cleaner with a damaged charging adapter cord or plug. Turn off all controls before plugging in or unplugging the vacuum cleaner to the adapter.
- 2** DO NOT use or charge unit outdoors or on wet surfaces. Use only on dry surfaces.
- 3** If vacuum cleaner is not working as it should, has been dropped, damaged, left outdoors, or dropped into water, return it to SharkNinja Operating LLC for examination, repair, or adjustment.
- 4** Always turn the vacuum off before connecting or disconnecting the floor nozzle.
- 5** DO NOT pull or carry the charging adapter by the cord or use the cord as a handle.
- 6** DO NOT unplug the charging adapter by pulling on the cord. Grasp the plug, not the cord.
- 7** DO NOT handle charging adaptor or vacuum cleaner with wet hands.
- 8** DO NOT run the vacuum cleaner over the charging adapter cord or close a door on the cord.
- 9** DO NOT use charging adapter with an extension cord.
- 10** Use only the charging adapter model XA1106 provided with the vacuum.
- 11** Keep charging adapter cord away from heated surfaces.
- 12** This product includes rechargeable Ni-Mh batteries. Batteries must be recycled or disposed of properly. DO NOT incinerate batteries or expose to high temperatures as they may explode.
- 13** Leaks from battery cells can occur under extreme conditions. If the liquid gets on the skin, wash immediately with soap and water. If the liquid gets into the eyes, flush them immediately with clean water for a minimum of 10 minutes and seek medical attention.
- 14** Do not place the batteries on metal surfaces.
- 15** Do not touch metal parts of the batteries together as the batteries will overheat.

# SAVE THESE INSTRUCTIONS

PLEASE READ CAREFULLY BEFORE USE

---

## GENERAL USE

- 16** Use only as described in this manual.
- 17** Keep your work area well lit.
- 18** Keep the vacuum cleaner moving over the carpet surface at all times to avoid damaging the carpet fibers.
- 19** DO NOT place vacuum cleaner on unstable surfaces such as chairs or tables.
- 20** DO NOT put any objects into openings. DO NOT use with any opening blocked; keep free of dust, lint, hair, and anything that may reduce airflow.
- 21** DO NOT allow the appliance to be used by children. Close attention is necessary when used near children. This is not a toy.

- 22** DO NOT use without dust cup and/or filters in place.

## DUST CUP/FILTERS/ACCESSORIES

Before turning on the vacuum:

- 23** Make sure that all filters are thoroughly dry after routine cleaning.
- 24** Make sure that dust cup and all filters are in place after routine maintenance.
- 25** Make sure accessories are free of blockages.
- 26** Only use Shark® brand filters and accessories. Failure to do so will void the warranty.

## GENERAL CLEANING

- 27** DO NOT vacuum up large objects.
- 28** DO NOT vacuum up hard or sharp objects such as glass, nails, screws, or coins that could damage the vacuum cleaner.
- 29** DO NOT vacuum up drywall dust, fireplace ash, or embers. DO NOT use as an attachment to power tools for dust collection.
- 30** DO NOT vacuum up smoking or burning objects such as hot coals, cigarette butts, or matches.
- 31** DO NOT vacuum up flammable or combustible materials (e.g., lighter fluid, gasoline, or kerosene) or use vacuum in areas where they may be present.
- 32** DO NOT vacuum up toxic solutions (e.g., chlorine bleach, ammonia, or drain cleaner).
- 33** DO NOT use in an enclosed space where vapors are present from paint, paint thinner, moth-proofing substances, flammable dust, or other explosive or toxic materials.
- 34** DO NOT vacuum up any liquids.
- 35** DO NOT immerse vacuum cleaner in water or other liquids.
- 36** Use extra care when cleaning on stairs.

# GETTING TO KNOW YOUR SHARK® ROTATOR® FREESTYLE PRO CORDLESS VACUUM

---

## WELCOME!

Congratulations on your purchase. Use this instruction manual to learn about your new vacuum's great features. From assembly to use to maintenance, you will find it all in here.

## MAIN UNIT

- A** Handle
- B** Main Body
- C** Screw
- D** Dust Cup Release
- E** Upper Dust Cup Door Release
- F** Dust Cup
- G** Lower Dust Cup Door Release
- H** Motorized Floor Nozzle
- I** Headlights
- J** Power Button/Surface Selector
- K** Charging Adapter
- L** Precision Charger Base

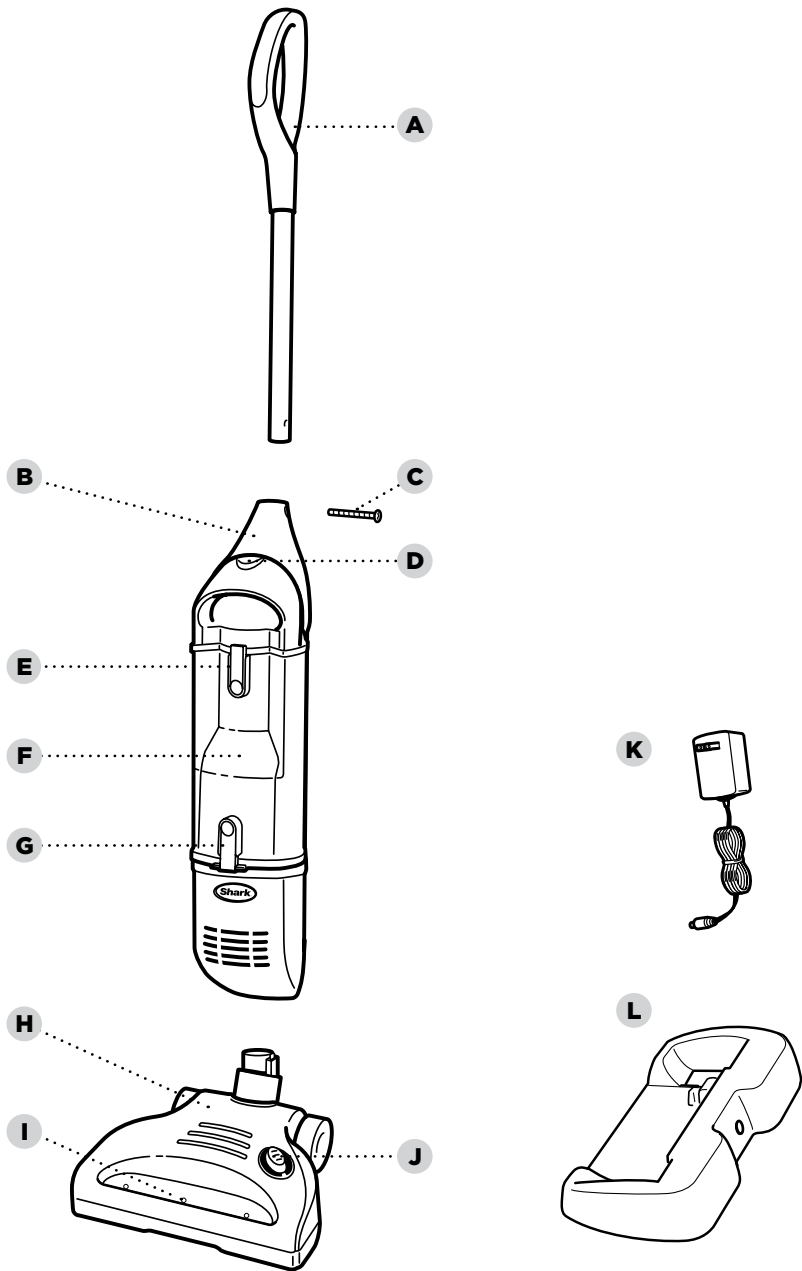

# ASSEMBLING YOUR VACUUM

 **TIP:** Before using vacuum, ensure the dust cup is securely in place.

 **TIP:** For the first use, give the vacuum a full charge. Depending on usage, the time for a full charge is 4 to 7 hours.

---

## HOW DO I KNOW WHEN THE VACUUM IS CHARGED?

**The entire oval blue light around the power button flashes.**

The unit is still charging.

**One half of the oval blue light around the power button flashes.**

The unit is fully charged.

### STEP 1

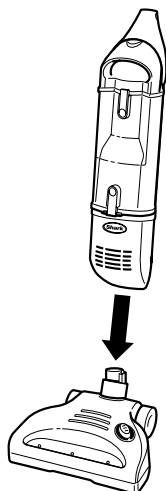

- 1** Insert vacuum body into floor nozzle.

### STEP 2

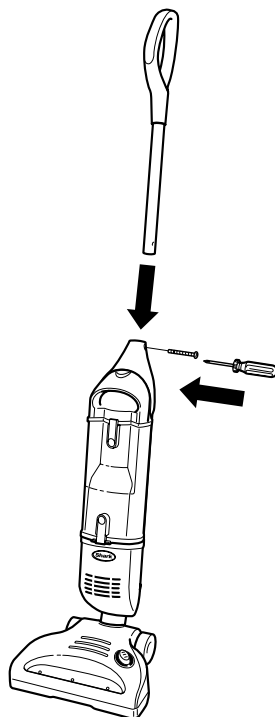

- 2** Insert handle pole into main body and secure by screwing in bolt (taped to handle during shipping).



---

**STEP 3**

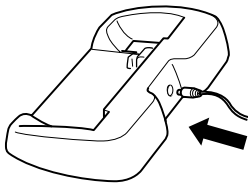

**STEP 4**

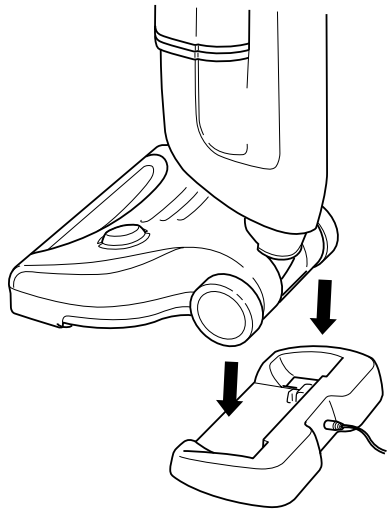

- 3** Insert the charging adapter plug by aligning the arrows on the plug and charging jack. Push in until it clicks into place.
- 4** Place vacuum on precision charger base.

# USING YOUR VACUUM

---

 **TIP:** The oval blue light around the power button will indicate which setting you are on.

On the high speed carpet setting, the vacuum will run for approximately 12 minutes.

On the lower speed bare floor setting, the vacuum will run for approximately 17 minutes.

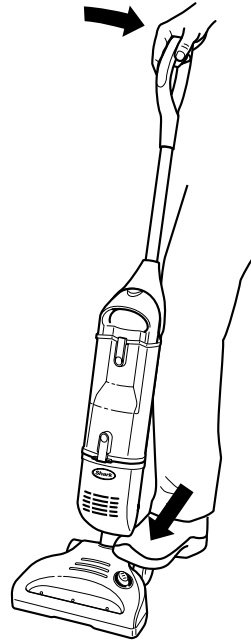

- 1** Place foot on floor nozzle and tilt handle back.

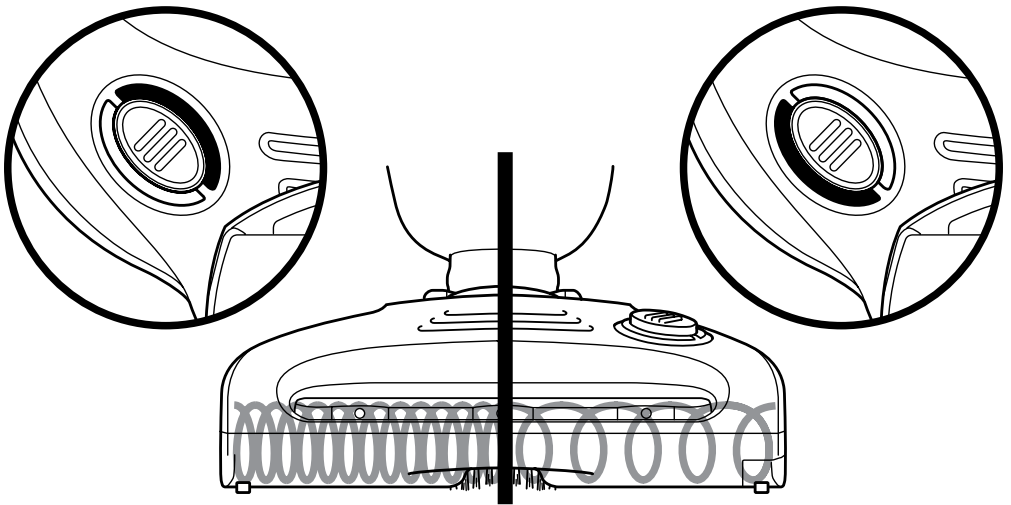

**2** Press the power button once to turn on the carpet setting. The brushroll will spin quickly in this mode to get deep carpet cleaning.

**3** Press the power button a second time to turn on the bare floor setting. The brushroll will spin slowly in this setting to vacuum up all of the surface litter on carpet and bare floors.

Press the power button a third time to turn off the vacuum.

# MAINTENANCE

To keep your vacuum's suction power optimal, follow these instructions. Make sure unit is off and is removed from the precision charger base.

.....

- ⚠ WARNING: DO NOT operate the vacuum with a wet filter.**
- DO NOT use a hair dryer or other forced hot air to dry the filter.**
- DO NOT operate vacuum without the filter in place.**
- .....

## RECOMMENDED CLEANING SCHEDULE:

### Dust Cup

Empty dust cup after every use or as debris approaches the MAX FILL line.

If the dust cup door does not swing open after pressing the release button, press down on the tabs on either side of the button to release the door.

### Foam Filter

XF1100T

Clean the foam filter once per month.

## STEP 1

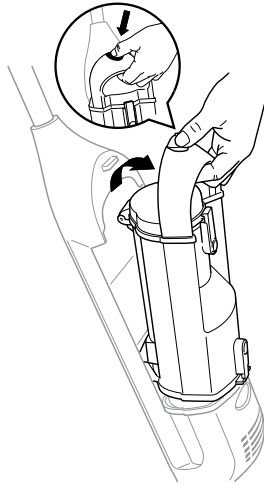

## STEP 2

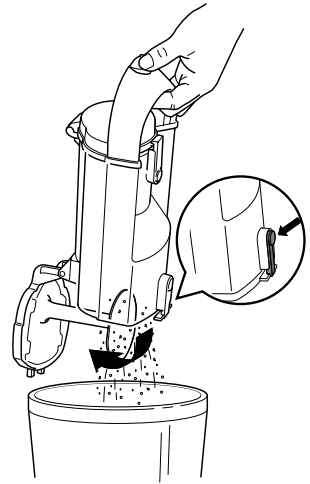

## EMPTYING THE DUST CUP

- 1** Press down on the dust-cup release button and lift dust cup out.
- 2** Hold dust cup over a trash bin and press the bottom dust-cup release latch.

---

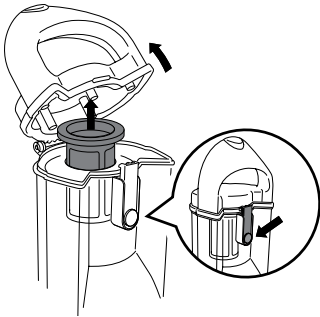
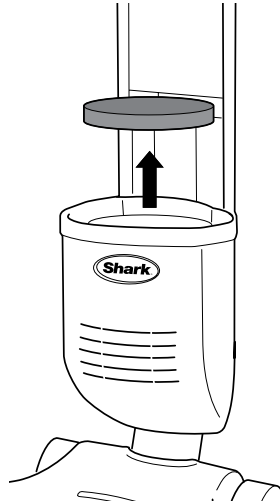
**STEP 3****STEP 1****STEP 2****CLEANING THE FILTER**

**3** Press the top dust-cup release latch and pull up on handle. Lift out metal screen and clear debris.

**1** Remove the dust cup, then remove the foam filter.

**2** Hand wash filter with water only. Squeeze excess water out and allow filter to air-dry completely before returning filter to the unit.

# MAINTENANCE



**TIP:** The brushroll is equipped with a raised cutting guide to easily cut hair and debris.

## STEP 1

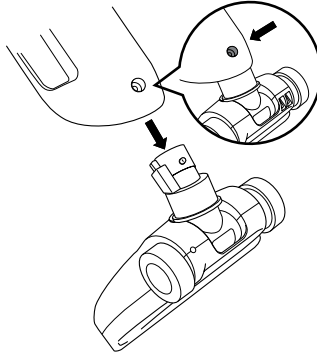

## STEP 2

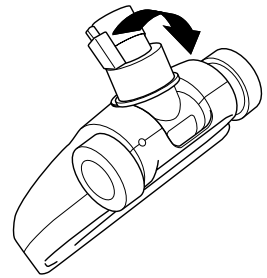

### BLOCKAGES IN NOZZLE

- 1** Press the release button on the rear of the main body and remove the floor nozzle.
- 2** Pull back the neck of the floor nozzle to straighten the air passage and remove debris.

---

### STEP 3

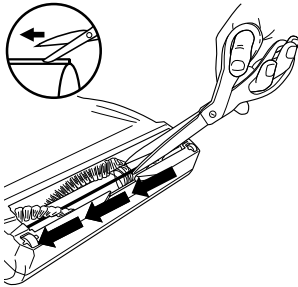

#### CLEANING THE BRUSHROLL

- 3** Flip the nozzle over to access brushroll. Use scissors to carefully remove hair and debris wrapped around the brushroll.

### STEP 4

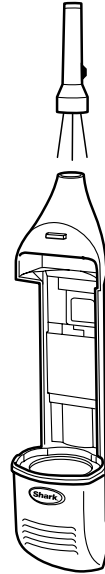

#### BLOCKAGES IN MAIN UNIT

- 4** You can also check for blockages in the main body. Just remove floor nozzle and dust cup and shine a flashlight in the opening.

# BRUSHROLL REMOVAL AND INSERTION

---

## STEP 1

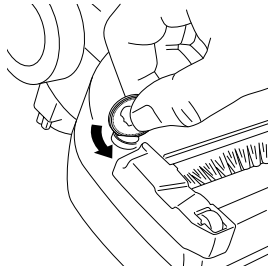

- 1** Use the edge of a coin to turn the dial near the brushroll access door to the unlocked position.

## STEP 2

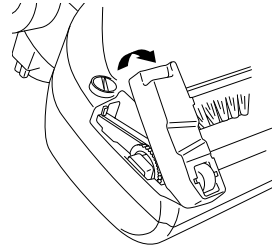

- 2** Remove brushroll access door.

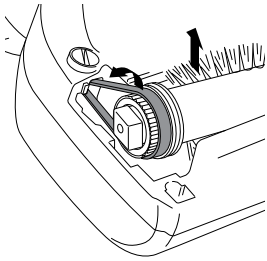
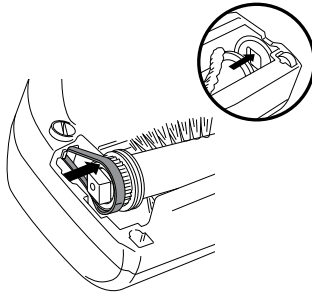
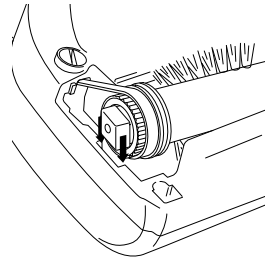

---

**STEP 3****STEP 4****STEP 5**

**3** Slip black belt off of white gear and lift out brushroll to clean off debris.

**4** Once the brushroll has been cleaned, reinsert by slipping the black belt back onto the white gear.

**5** Align the white square at the end of the brushroll with the slot near the belt. Fit the square into the slot.

# BATTERY PACK REPLACEMENT & DISPOSAL

---

**⚠ WARNING: The Cordless vacuum is powered by Ni-Mh batteries, which must be recycled or disposed of properly in accordance with state, federal and local laws.**

**If uncertain how to remove the battery pack, we suggest you take your hand vacuum to a reputable small appliance service technician to have this service performed.**

**⚠ WARNING: Never use ordinary batteries for replacement as these may leak and damage your vacuum. Use only the battery pack provided by SharkNinja for replacement.**

**⚠ WARNING: Do not store or charge in areas of high temperature or humidity.**

.....

## **Replacement Battery Part Number**

XBT1106

## **Charging Adapter Part Number**

XA1106

## **MAXIMIZING THE LIFE OF YOUR BATTERY**

- 1** This vacuum is equipped with an advanced feature that will shut off the vacuum when the battery is almost fully discharged. If the vacuum shuts off while in use, charge the unit until one half of the oval blue light around the power button flashes, indicating a full charge.
- 2** Charge the vacuum for 7 hours before initial use. After initial use, each recharge will take 4 to 7 hours because the charger monitors battery properties to extend battery life. The entire oval LED light around the power button will flash every 2 seconds while the unit is charging. When the charge is complete, one half of the oval will flash every 2 seconds.
- 3** The precision charger monitors the batteries so you don't have to. Leaving the unit charging past the complete charge time will NOT harm the batteries.
- 4** If the vacuum has never been used or has not been used for an extended period of time, it will take 3 to 5 complete charge and run-down cycles to realize the full operational time of the vacuum.
- 5** Use only the charge adapter supplied with this unit, marked with "For SV1112 series models only". If other chargers are used, the battery can fail, causing damage to the battery, to the vacuum, or to personal property.

---

## STEP 1

## STEP 2

## STEP 3

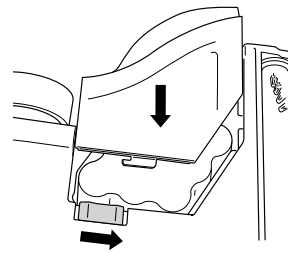
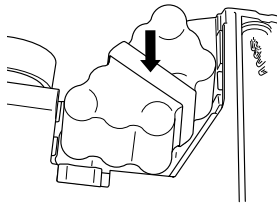
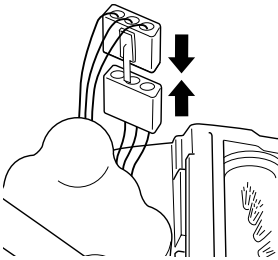

- 1** Push the connector terminals together until they lock into place.
- 2** Place the new battery pack into the battery compartment, taking care to tuck the wiring completely so that it does not interfere with the battery access door.
- 3** Place the battery door onto the bottom of the nozzle, slide it back into place and move the sliding tab next to the door to the lock position.

# TROUBLESHOOTING GUIDE

---

**⚠ WARNING: To reduce the risk of shock and unintended operation, turn power off and unplug unit before servicing.**

## **Vacuum is not picking up debris. No suction or light suction.**

**(Refer to Maintenance section for more information.)**

- Check filters to see if they need cleaning. Follow instructions for rinsing and drying the filters before re-inserting in the vacuum.
- Dust cup may be full; empty dust cup.
- Remove any string, carpet fibers, or hair that may be wrapped around the brushroll.
- Check for blockages in the dust cup filter and floor nozzle.
- Make sure that the battery is fully charged.

## **Vacuum will not operate.**

- The battery may be depleted. Charge the vacuum until half of the oval light flashes, indicating full charge.
- The brushroll may be jammed. Turn the unit off and allow it to cool down for 10 seconds.
- Ensure nothing is blocking the motorized brush or wrapped around the brushroll.

## **Charging indicator does not illuminate.**

- Check to see if the charge adapter is plugged in properly to the outlet and to the charging jack.
- Ensure there is no debris accumulated on the metal charge contacts on the floor nozzle or charging adaptor.
- Ensure that the electrical outlet is supplying power to the charger.

## **Motorized brush will not work.**

- The floor nozzle may have blockage; See “Clearing Blockages”.
- Ensure that the floor nozzle is properly attached.

## **Dust escapes from vacuum.**

- Empty the dust cup container.
- Ensure that the filter is inserted completely into its holder below the dust cup.
- Check for punctures in dust cup filter or cracks in the dust cup and replace if necessary.

## **Vacuum turns off on its own.**

- Charge the unit until half of the oval flashes, indicating a full charge.

## **Run Time has decreased over time.**

If you experience shorter run time over the life of the vacuum, perform the following battery reconditioning steps. These steps can also be performed as monthly maintenance for maximum battery life.

- Make sure the vacuum is fully charged (this could take up to 7 hours).
- Run vacuum until it turns itself off.
- Fully charge the vacuum again.





# Shark | NINJA ONE (1) YEAR LIMITED WARRANTY

---

The 1-Year Limited Warranty applies to purchases made from authorized retailers of **SharkNinja Operating LLC**. Warranty coverage applies to the original owner and to the original product only and is not transferable.

SharkNinja warrants that the unit shall be free from defects in material and workmanship for a period of 1 year from the date of purchase when it is used under normal household conditions and maintained according to the requirements outlined in this instruction manual, subject to the following conditions and exclusions.

## What is covered in my warranty?

1. The original unit and/or non-wearable components deemed defective, in SharkNinja's sole discretion, will be repaired or replaced for up to 1 year from the original purchase date.
2. In the rare event that a replacement unit is issued, the warranty coverage ends six months following the receipt date of the replacement unit, or the remainder of the existing warranty, whichever is greater. If the unit is replaced, SharkNinja reserves the right to replace the unit with one of equal or greater value.

## What is not covered in my warranty?

Our Customer Care/Product Specialists are available to provide all the warranty service options available to you, including the possibility of upgrading to our VIP Warranty Service Options for select product categories.

1. Normal wear and tear of wearable parts such as foam as filters, HEPA filters, pads etc., which require regular maintenance and/or replacement to ensure the proper functioning of your unit are not covered by this warranty.
2. Any unit that has been tampered with or used for commercial purposes.
3. SharkNinja will cover the cost for the customer to send in the unit to us for repair or replacement. A fee of \$19.95 for return shipping costs will be charged at the time of return shipment of the repaired or replacement unit.
4. Damage caused by misuse, abuse, or negligent handling, or damage due to mishandling in transit.
5. Consequential and incidental damages.
6. Defects caused by or resulting from damages from shipping or repairs, service, or alteration to the product or any of its parts which have been performed by a repair person not authorized by SharkNinja.
7. Products purchased, used or operated outside of North America.

## Problems with your unit/How to get service

If your appliance fails to operate properly while in use under normal household conditions within the warranty period, visit [sharkclean.com](http://sharkclean.com) for product care/maintenance self-help. Our customer care and product specialists are also available at 1-800-798-7398 to assist with product support and warranty service options.

## How to initiate a warranty claim

You can call 1-800-798-7398 to have a customer care specialist assist you. Please note you must call 1-800-798-7398 to initiate a warranty claim. Return and Packing Instruction information will be provided at that time.

Replacement parts are available for purchase at [sharkclean.com](http://sharkclean.com). For more information on what are classified as wearable and non-wearable parts, please visit [sharkwarranty.com](http://sharkwarranty.com).

This warranty gives you specific legal rights, and you also may have other rights that vary from state to state.

Some states do not permit the exclusion or limitation of incidental or consequential damages, so the above may not apply to you.



**SharkNinja Operating LLC**  
**US: Newton, MA 02459**  
**CAN: Ville St-Laurent, QC H4S 1A7**  
**1-800-798-7398**  
**sharkclean.com**

Illustrations may differ from actual product. We are constantly striving to improve our products; therefore the specifications contained herein are subject to change without notice.

Shark and Rotator are registered trademarks of SharkNinja Operating LLC.

For SharkNinja U.S. Patent information visit  
[sharkninja.com/USPatents](http://sharkninja.com/USPatents)

